

## CONTENTS

- 1.Introduction
- 2.Installation Guidelines
- 3.Using Inverter
- 4.Troubleshooting
- 5.Specifications

### **Safety First**

Incorrect installation or misuse of the inverter may result in danger to the user or hazardous conditions. We urge you to pay special attention to all CAUTION and WARNING statements. CAUTION statements identify conditions or practices that may result in damage to other equipment, WARNING statements identify conditions that may result in personal injury or loss of life .

#### **AWARNINGI Shock hazard. Keep away from children.**

- The inverter generates the same potentially lethal AC power as a normal household wall outlet. Treat it with the same respect that you would any AC outlet.
- Do not insert foreign objects into the inverter's AC outlets, fan or vent openings.
- Do not expose the inverter to water, rain, snow or spray.
- Do not, under any circumstances, connect the inverter to utility power AC distribution wiring.

#### **WARNING! Heated surface.**

- The inverter's housing may become uncomfortably warm, reaching 140° F (60° C) under extended high power operation. Ensure at least 2 inches (5cm) of air space is maintained on all sides of the inverter. During operation, keep away from materials that may be affected by high temperatures.

#### **WARNING! Explosion hazard.**

- Do not use the inverter in the presence of flammable fumes or gases, such as in the bilge of a gasoline powered boat, or near propane tanks. Do not use the inverter in an enclosure containing automotive-type, lead-acid batteries. These batteries, unlike sealed batteries, vent explosive hydrogen gas, which can be ignited by sparks from electrical connections.
- When working on electrical equipment always ensure someone is nearby to help you in an emergency.

#### **CAUTION!**

- Do not connect live AC power to the inverter's AC outlets. The inverter will be damaged even if it is switched OFF.
- Do not connect any AC load, which has its neutral conductor connected to ground, to the inverter.

- Do not expose the inverter to temperatures exceeding 104° F (40° C).

 **CAUTION! Do not use inverter with the following equipment.**

- Small battery operated products such as rechargeable flashlights, some rechargeable shavers, and night-lights that are plugged directly into an AC receptacle to recharge.
- Certain battery chargers for battery packs used in hand powered tools. These chargers will have warning labels stating that dangerous voltages are present at the charger' s battery terminals.
- Connect inverter only to batteries with a 12V/24V/48V DC nominal output. A battery with 6V/12v/24v nominal output will not supply enough voltage and a battery with 24V/48V/96V nominal output will DAMAGE THE INVERTER.

## 1. Introduction

Thank you for purchasing the power inverter. The inverter is a compact and highly portable power inverter, the leader in the field of high frequency inverter design. From the 12V/24V/48V DC outlet in your vehicle or boat, or directly from a dedicated 12V/24V/48V DC battery, the inverter will efficiently and reliably power a wide variety of household AC products, such as TVs, computers, VCRs, and includes automatic safety monitoring circuitry to protect the inverter, and your battery, from inadvertent overload conditions.

Read this guide before installing or using the inverter and save it for future reference.

### Safety Features

These advanced safety features are built into the inverter:

- Electronic overload protection with automatic shutdown.
- Built-in internal backup DC fuse provides added safety.
- Low battery voltage protection with automatic shutdown.
- Over temperature protection with automatic shutdown.
- Output short circuit protection.

## 2. Installation Guidelines

### Selecting a Suitable Location

For safe and optimum performance, install the inverter in a location that is:

- Dry. Do not expose to water drip or spray.
- Cool. Operate only in ambient temperatures between 32° F (0° C) and 104° F (40° C). Keep away from furnace heating vents or other heat producing equipment.
- Well ventilated. Allow at least 2 inches (5cm) clearance above and on all sides of the unit for proper cooling.
- Safe. Do not install inverter in a compartment with batteries or flammable

liquids, such as gasoline, or explosive vapors.

- Clean and free of dust and dirt. This is especially important if the Jazz inverter is used in a work environment.

### Using the DC Cable-Plug

Due to limitations in the common 12V/24V/48V DC outlet in a vehicle or boat, the inverter should only be used to supply AC power to products that require the rated continuous power or less. If your application requires more than the rated continuous power (but less than the rated continuous power) or has a high start-up surge, see Using the DC Cable-Clips.

1. Attach the ring type connector marked with red to the positive (+) DC terminal on the inverter and attach the ring connector marked with black to the negative (-) DC terminal.

 **CAUTION!** A reverse polarity connection (positive to negative) may damage the inverter. Damage caused by a reverse polarity connection is not covered under warranty.

2. Tighten the nut on each DC terminal by hand until it is snug. Do not over tighten.
3. Insert the plug of this cable into the 12V/24V/48V DC outlet and switch the unit ON. See Section 4 if the inverter does not operate properly after being connected.
4. When the inverter is not in use, unplug it from the 12V/24V/48V DC outlet to prevent slight discharge of the Battery.

### Instruction of structure

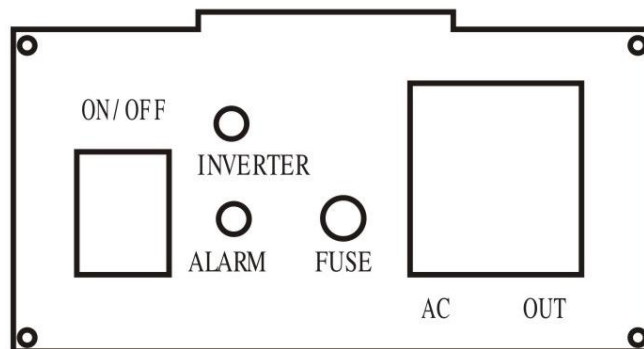

### Instruction of operation

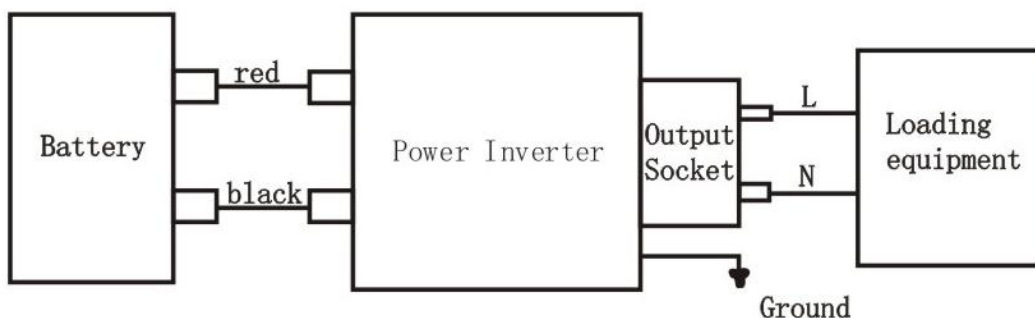

## Using the DC Cable-Clips

By directly connecting the inverter to a 12V/24V/48V DC battery with DC Cable-Clips, you can operate products with power requirements up to rated continuous output power. If you want to permanently connect the inverter to a battery, contact customer service.

1. Follow steps 1 and 2 above (Using the DC Cable-Plug) to attach the ring type connectors.
2. Attach the black negative clip to negative (-) battery terminal.
3. Attach the red positive clip to the positive (+) battery terminal. Make sure both clips are securely connected to the battery terminals, as a loose connection will cause excessive voltage drop and may cause the cables to overheat resulting in equipment damage or fire.
4. Switch the inverter ON. See section 4 if the inverter does not operate properly after being connected.
5. When the inverter is not in use, disconnect the DC Cable-Clips from the battery.

### **3. Using Inverter**

The inverter is capable of continuously powering most 110V/230V AC products that use the rated continuous output power or less. Its AC output waveform, called "modified sine wave/pure sine wave" is designed to function as wave shape of utility power, or more beautiful than city electricity.

The power, or "wattage", rating of AC products is the average power they use. When many AC products are first switched on, they initially consume more power than their power rating. TVs, monitors, and electric motors are examples of products that have high "surge" requirements at start up. Although the inverter can supply momentary surge power as high as surge power, occasionally some products rated less than the rated continuous output power may exceed its surge capabilities and trigger its safety overload shutdown feature. If this problem occurs when attempting to operate several AC products at the same time, try first switching on inverter with all AC products switched off, then one by one switch each on, starting with the high surge product first.

### Indicators and Controls (see Figure 1)

- The AC outlets are provided on one end of the inverter. Any combination of 110V-120V/220-240VAC products with a total continuous power consumption of the continuous power or less may be plugged in.
- The ON/OFF switch enables output AC power at the AC outlets when switched ON.
- The green POWER light indicates AC power is present at the AC outlets and the inverter is operating normally.
- The red FAULT light indicates inverter shutdown caused by low or high voltage, overload or excessive temperature.

## Inverter operation

1. When properly connected to a 12V/24V/48V DC outlet or battery, turning the ON/OFF switch ON, will illuminate the green POWER light, and AC power to the outlets.
2. Plug the AC product(s) you wish to operate into the AC outlet(s) and switch them on, one at a time.
3. As the battery charge is used up, battery voltage begins to fall. When the inverter senses that the voltage at its DC input has dropped to 10~10.5V/20~21V/40~42V, an audible alarm sounds. This allows time for computers or other sensitive devices to be shut down.
4. If the audible alarm is ignored the inverter will automatically shut down when the battery voltage drops to 9.8~10.2V/19.6~20.4V/39.2~40.8V. This prevents battery damage from excessive discharge. After auto shut down, the red FAULT light illuminates.

**⚠ IMPORTANT: Vehicle batteries are designed to provide brief periods of very high current needed for engine starting. They are not intended for constant deep discharge. Regularly operating the inverter shortens the life of the battery. Consider connecting the inverter to a separate deep discharge type battery if you will be frequently running electrical products for extended periods of time.**

5. If an AC product rated higher than the rated continuous power (or which draws excessive surge power) is connected, the inverter will shut down. The red FAULT light will turn on.
6. If the inverter exceeds a safe operating temperature, due to insufficient ventilation or a high temperature environment, it will automatically shut down. The red FAULT light will turn on and the audio warning will sound.
7. Should a defective battery charging system cause the battery voltage to rise to dangerously high levels, the inverter automatically shuts down.

**⚠ CAUTION! Although the inverter incorporates protection against over-voltage, it may still be damaged if the input voltage exceeds 16 volts/32 volts/64 volts.**

8. The cooling fan is designed to operate only when the temperature is higher than 40° C.
9. In the event of an overload, low battery voltage or overheating, the inverter will automatically shut down (See Section 4).

## Battery Operating Time

Operating time will vary depending on the charge level of the battery, its capacity and the power level drawn by the particular AC load.

When using a battery as a power source, it is strongly recommended to start the vehicle every hour or two to recharge the battery before its capacity drops too low.

The inverter can operate while the engine is running, but the normal voltage drop that occurs during starting may trigger the inverter's low voltage shut down feature. Because the inverter draws less than the no load current draw with the ON/OFF switch in ON position and with no AC products connected, it has minimal impact on battery operating times.

### Interference with Electronic Equipment

Generally, most AC products operate with the inverter just as they would with household AC power. Below is information concerning two possible exceptions.

#### Buzzing Sound in Audio Systems and Radios

Some inexpensive stereo systems, "boom boxes", and AM-FM radios have inadequate internal power supply filtering and "buzz" slightly when powered by the inverter. Generally, the only solution is an audio product with a higher quality filter.

#### Television Interference

The inverter is shielded to minimize its interference with TV signals. However, with weak TV signals interference may be visible in the form of lines scrolling across the screen. The following should minimize or eliminate the problem:

- Use an extension cord to increase the distance between the inverter and the TV, antenna and cables.
- Adjust the orientation of the inverter, television, antenna and cables.
- Maximize TV signal strength by using a better antenna and use shielded antenna cable where possible.
- Try a different TV. Different models of televisions vary considerably in their susceptibility to inverter interference.

## 4. Troubleshooting

**PROBLEM:** AC product will not operate.

<b>Possible Cause</b>	<b>Suggested Remedy</b>
Battery is defective.	Check battery and replace if required.
Inverter has been connected with reverse DC input polarity.	Check connection to battery. Probable inverter damage has occurred. Have unit repaired (not covered by warranty).
Loose cable connections.	Check cables and connections. Tighten as required.

**PROBLEM:** Inverter will run some small loads, but not large ones.

<b>Possible Cause</b>	<b>Suggested Remedy</b>
Voltage drop across DC cables.	Shorten cables or use heavier cables.

**PROBLEM:** Alarm is sounding.

**Possible Cause**

Low voltage shutdown or thermal shutdown has occurred.

**Suggested Remedy**

Shorten cables or use heavier cables. Recharge battery. Allow unit to cool. Improve air circulation around unit. Locate unit to cooler environment. Reduce load if continuous operation is required.

**PROBLEM:** Battery run time is less than expected.

**Possible Cause**

AC product power consumption is higher than rated.

Battery is old or defective.

Battery is not being properly charged.

Power dissipation in DC cables.

**Suggested Remedy**

Use a larger battery to make up for increased power requirement.

Replace battery.

Many simple chargers are unable to charge a battery fully. Replace charger with a better model such as a TRUECHARGE smart charger.

Use shorter/heavier DC cables.

**PROBLEM:** AC product will not operate, red FAULT light ON.

**Possible Cause**

Continuous power overload protection for connected AC products with a power greater than the rated output of the transformer

External product exceeds the peak of the inverter

The power of the connected AC product is less than the peak rated output continuous power of the inverter leading to overload protection

Dead battery (alarm sounds)

Poor ventilation of the inverter, resulting in over-temperature protection

**Suggested Remedy**

Use rated power less than the inverter's rated output continuous power

Use start-up peaks within the inverter's rated peak range

Use start-up peaks within the inverter's rated peak range

Battery Recharge

Switch off the inverter and allow the plastic converter to cool down for 15 minutes Clean the inverter phoenix says book one open cover food and put it in a place with a slightly lower ambient temperature to reduce the load If you want to continue to use it, restart the inverter.

## 5. Specification

Specification	Value
Max continuous power	800W
Peak Power	1600W
No load current draw	< 0.6A
Input DC voltage Range	DC12V/24V $\pm$ 2V
Output Voltage Range	AC110V/220V $\pm$ 5%
Output Frequency Range	50/60Hz $\pm$ 3Hz
USB output	DC 5V (0.5A, 1A, 2.1A)
Output waveform	Modified sine wave
Max Outer Temperature	< 75° C
Max Power Efficiency	> 86%
High Voltage Cut Off Level	15V/27V $\pm$ 1V
Low Voltage Alarm Level	10.5V/22.5V $\pm$ 0.3V
Low Voltage Cut Off Level	10V/22V $\pm$ 0.3V
Overload and Short-circuit Protection	Yes
Input Voltage	DC 12V/24V
THD	$\leq$ 5%
Built-in Cooling Fan	Yes